



## Slow Speed Granulators



**ZERMA**

The Home of Size Reduction

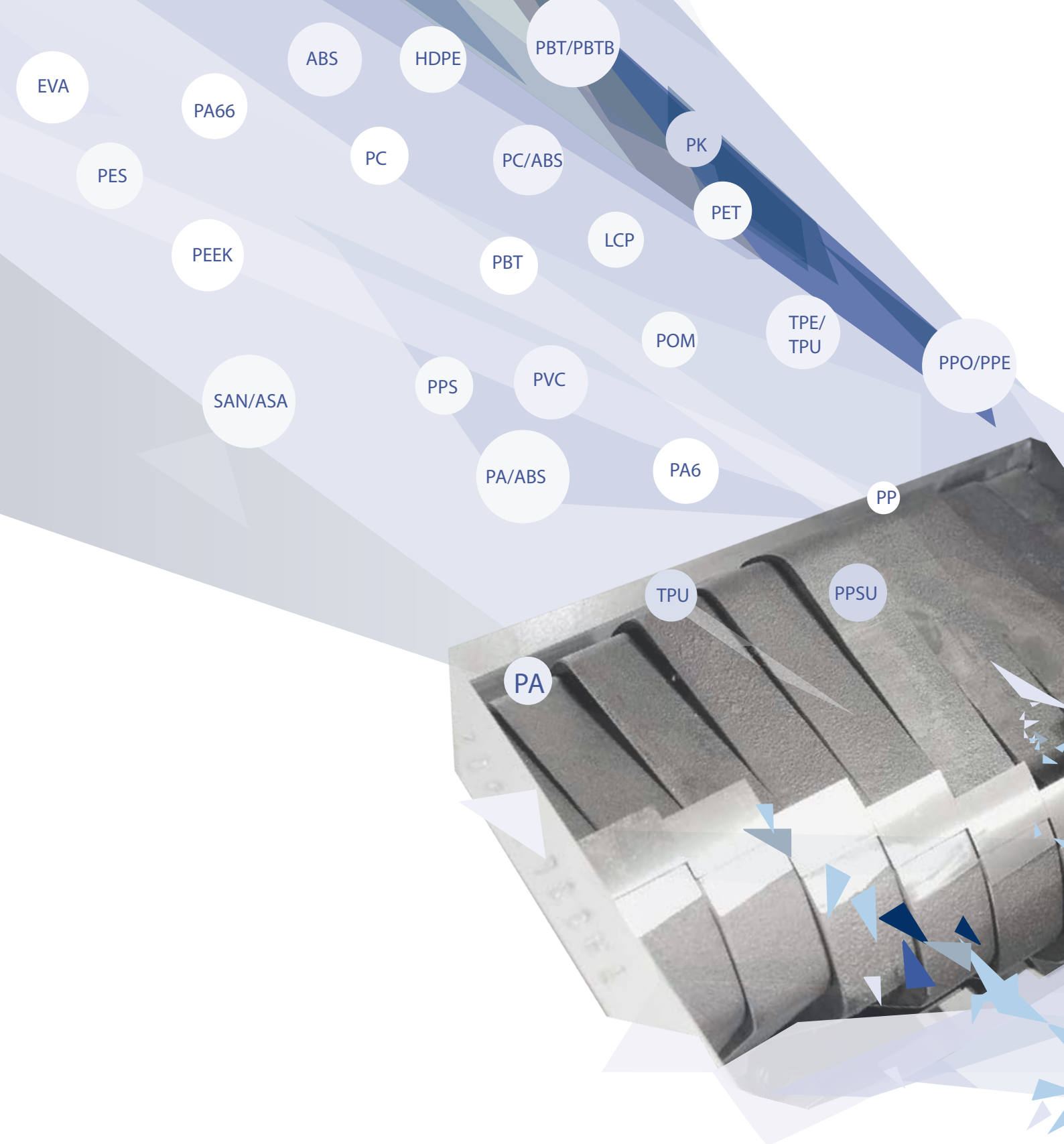

**GSL series key characteristics:**

- Low noise due to the low rotor speed, staggered rotor blades and sound dampening hopper in sandwich construction
- Powerful efficient power transmission using high quality geared motors
- Simple maintenance, cleaning and blade change

# Granulators designed for inline applications

The low speed granulators of the GSL series are designed to recycle rejects and scrap in injection and blow molding applications. Various hopper and discharge designs allow a flexible and customized implementation of the machines.



# Application Examples

## Injection molding

GSL beside-the-press granulators are used to grind sprues or reject parts directly at the injection molding machine. The resulting regrind can be immediately reintroduced into the production process.

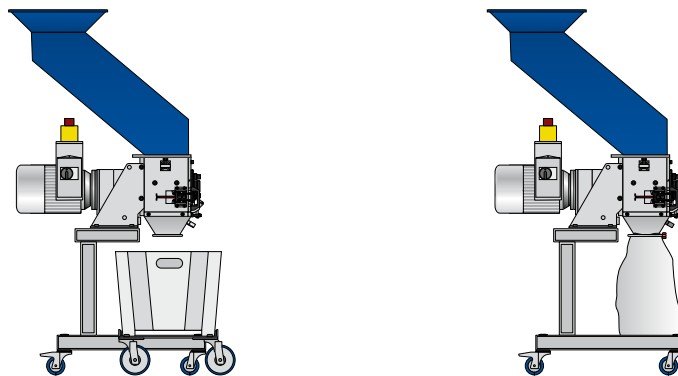
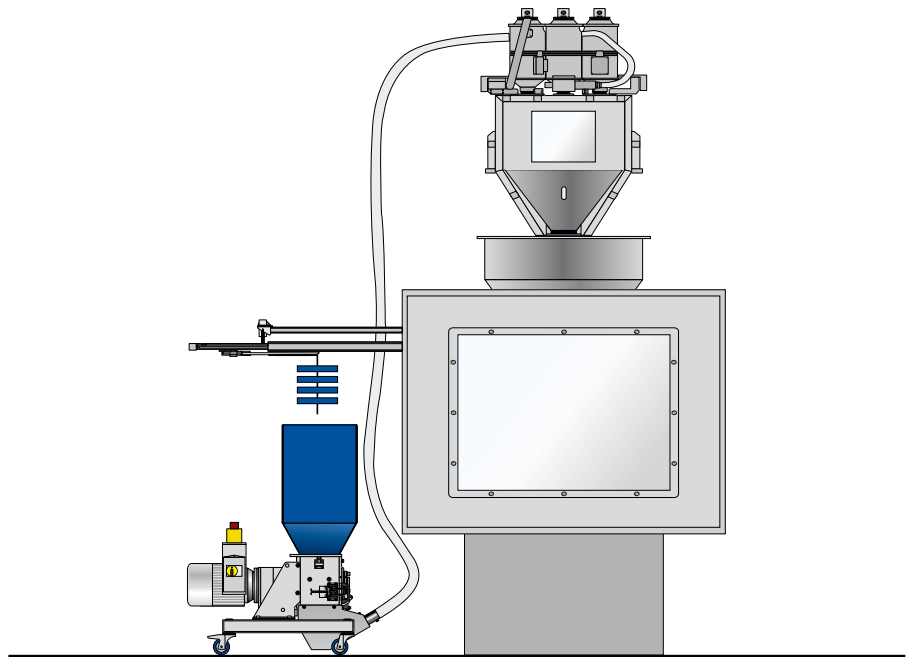

## Mobile grinding solution

The granulators are mounted on heavy-duty casters to allow for flexible placement and easy moving. For short production runs or frequent color or material changes the machines can optionally be equipped with a high frame and discharge into bins or bags.



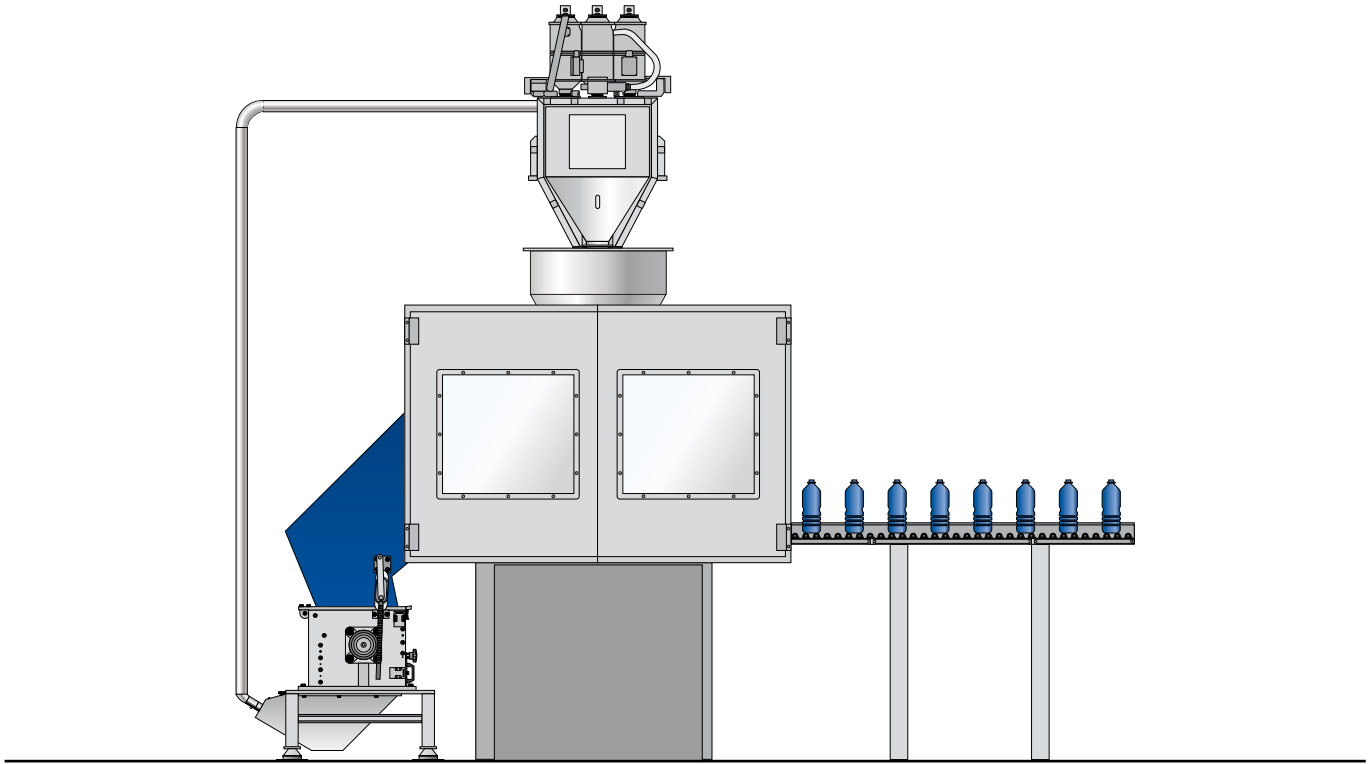

### Customer and application specific solutions

Due to the modular design of the machines the hopper and discharge can be customized according to specific requirements. Allowing for direct feeding without conveyors or robots.

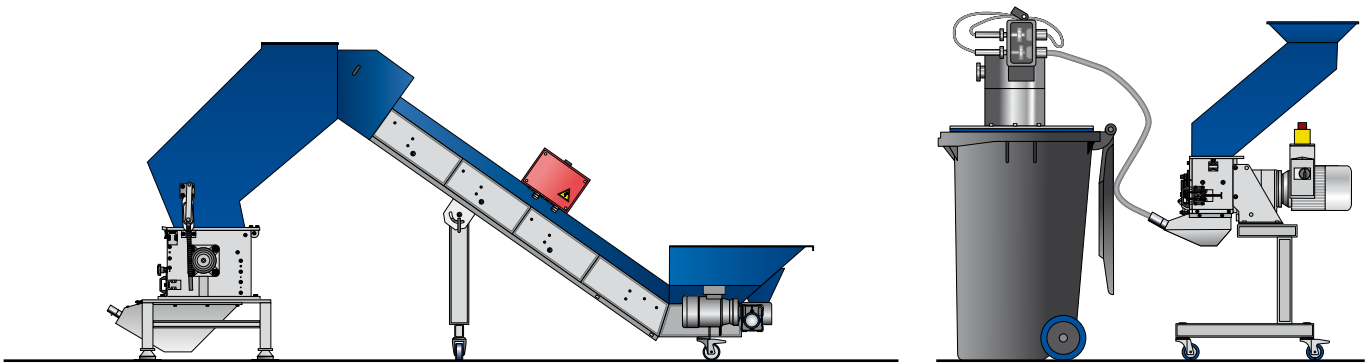

### Optional accessories

GSL slow speed granulators can be customized further into specific applications by a wide range of accessories such as conveyors, metal detectors and different methods of material extraction.

# Proven technology – Ideal results

# Our beside-the-press granulators

The slow-speed granulators of the GSL series operate at a low rotor rpm ensuring a minimal noise level and the highest quality virtually dust free regrind.

The specially designed rotor knives can be resharpened several times and due to their unique design do not require any adjustment when installing in the granulator after sharpening.

The material to be processed is introduced into the machine via a light-weight sound dampening hopper built in sandwich construction. The screen mounted at the bottom of the cutting chamber regulates the final size of the granulated material.

The regrind is collected in a stainless steel bin, which can be emptied with normal vacuum systems.



## Advantages:

- Specially designed rotor knives simplify maintenance and reduce downtime
- Tool-less access to the machine for maintenance and cleaning
- Low noise emission due to slow speed and sound dampening hopper
- Modular design allows for customization

**GSL 180**

### **Easy maintenance and cleaning**

Access to the cutting chamber and screen is quick and easy without the need for tools.

Seals and high precision manufacturing ensure a clean machine environment.

### **Safety**

All machines are designed according to latest statutory safety standards to avoid operation while the cutting chamber is accessible.



**GSL 300**

# **Reliable technology – Reliable quality**

# GSL180 Series

The slow speed granulators of the GSL180 series feature a closed 180 mm diameter rotor with width range options from 120 to 430 mm.

The rotors are comprised of single discs arranged on an oversized drive shaft connected to the gear motor. This allows for efficient and low maintenance power transmission.

The material can be fed manually, by conveyor or by robot into the large sound dampening hopper. Typically the machines are placed on a low frame with integrated heavy duty casters. Discharge of the material is accomplished via vacuum system from the integrated stainless steel material collection bin.

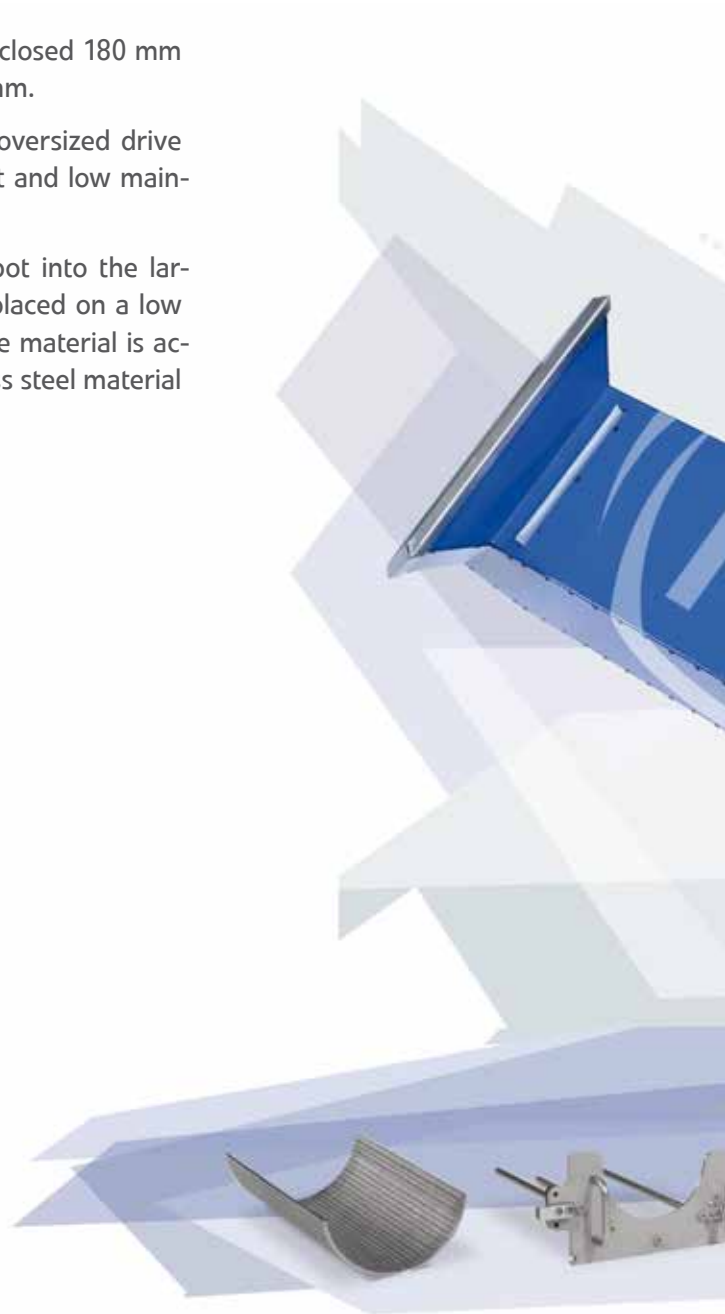

## Applications

The slow speed granulators in the GSL180 series are specifically designed for the processing of runners, sprues and rejects in injection molding processes. The safe, easy access to the cutting chamber allows for quick changeovers in case of material or color changes. The low rotor speed allows processing of pliable as well as rigid materials and ensures high quality regrind with low dust.





**The classic – Capable and versatile**

# GSL 300 series

The slow speed granulators in the 300 series feature a 300 mm diameter rotor with widths ranging from 400 - 800 mm. The rotor is directly driven by a geared motor. This ensures smooth operation even when processing challenging materials.

The low rotor speed generates less noise and a high quality, low dust re-grind. The specifically designed rotor knives can be sharpened multiple times and can be installed in the machine without readjustment of the cutting system.

The Quick-Snap system and large knobs allow fast and easy access to the cutting chamber without the need for tools.

The material is introduced into the machine via a sound dampening hopper. The machines can be customized depending on the application with different hoppers and discharge options.

## Applications

The slow speed GSL300 series are well suited for the processing of production scrap as well as voluminous parts. They can also be used as central granulator for low volume production or in laboratory environments.

The sturdy construction and high torque of the GSL300 series allows processing of heavier, thick walled and other challenging materials.





**Sturdy design –  
For demanding tasks**

# Well considered and efficient – Details

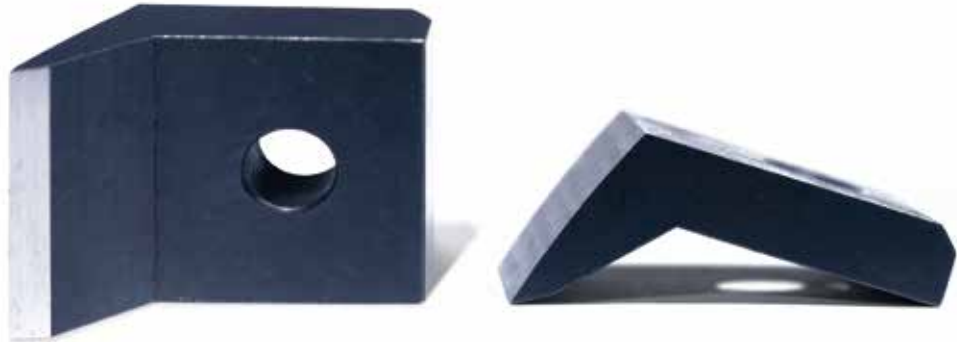

## Unique knife design simplifies maintenance

The rotor is equipped with specially designed knives. The curvature of the knives ensures a constant cutting gap even after sharpening without the need to readjust the rotor knives.

## Sturdy rotor

The rotor shaft is supported on both ends by heavy duty bearings. Due to the modular design of the rotor the shaft is sized for the widest machine ensuring performance and longevity across the whole range.

The staggered design of the rotor means that a maximum of 2 blades cut at any one time thus reducing the stress on the rotor.

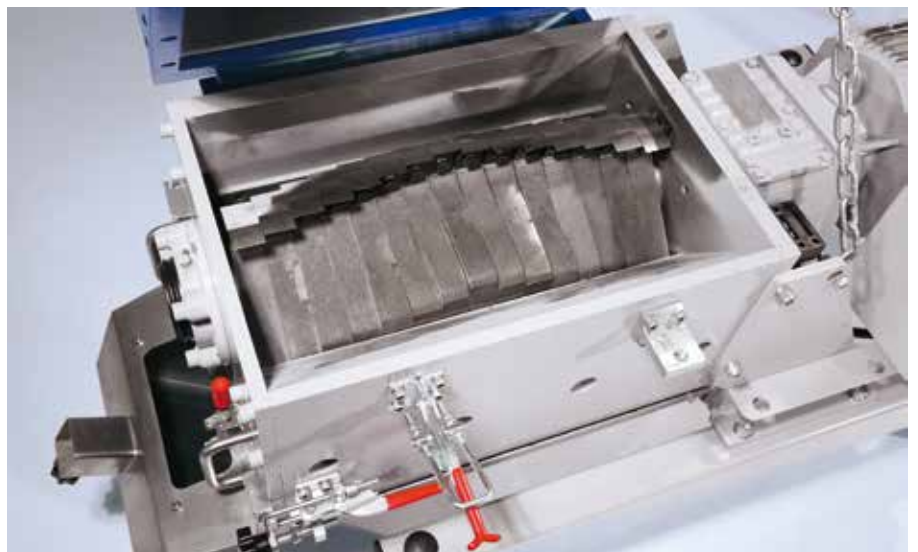

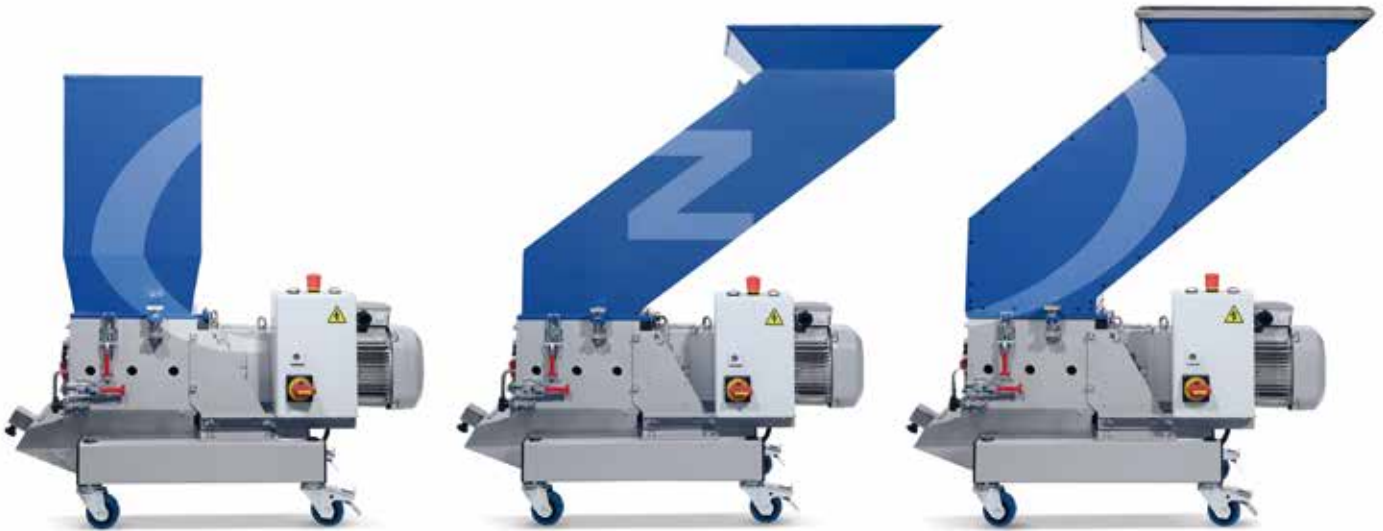

### Sound dampening hopper

All GSL granulators are equipped with lightweight sound dampening hoppers featuring sandwich construction of a thick layer of sound dampening material between two sheets of stainless steel.

The standard hoppers allow feeding by hand or robot.



### Quick-Snap system

The proven ZERMA quick-snap system allows a quick and easy opening of the machine and removal of the front plate to gain access to the screen. This allows simple cleaning when changing color or material.

Safety switches avoid starting of the machine when the cutting chamber or rotor are exposed.



# Quality is not optional!



## High quality components

Drive system and controls are comprised of high quality name brand components to ensure a long service life plus world wide service coverage plus compliance with safety regulations around the globe.

## Sound proofing

Optionally the GSL granulators can be equipped with complete sound proofing cabin and doors to further reduce the operational noise.



## Built-in blower system

GSL granulators can optionally be equipped with a built-in blower system to move the granulated material to a bag or a silo.



### Compact mobile design

The granulators in the 180 series are designed as very compact units. Combined with the heavy duty wheels this allows for flexible placement. They can be moved around easily during tool change and maintenance on the injection molding machines.



### High-frame option

All GSL granulators can be placed on a high frame allowing discharging into bags, bins or boxes.



### Compact unit

The GSL granulators are not only used in plastic processing applications. The 'heart' of the GSL can be used for different applications as well:

For example, the Household Waste Processor is designed for camping or maritime applications. Here the cutting chamber is fully integrated into the system, thus removing the need for the customer to interact with the machine directly, and where packaging waste is placed into the feeding bin, processed in batches and automatically collected in waste bags thus allowing a volume reduction of such packaging waste.



# Technical Data

## Series GSL 180

Type	180/120	180/180	180/300	180/430
Rotor diameter (mm)	180	180	180	180
Rotor width (mm)	120	180	300	430
Rotor speed (rpm)	150	150	150	150
Drive capacity (kW)	2,2	3	4	4
Rotor knives (pcs)	12	18	30	45
Stator blades (rows)	2	2	2	2
Screen size (mm)	>5	>5	>5	>5
Weight approx. (kg)	130	140	180	250

## Dimensions

Type	180/120	180/180	180/300	180/430
A (mm)	865	865	915	915
B (mm)	770	770	770	770
C (mm)	515	515	515	515
D (mm)	535	535	535	535
E (mm)	345	405	520	655
F (mm)	600	660	800	940

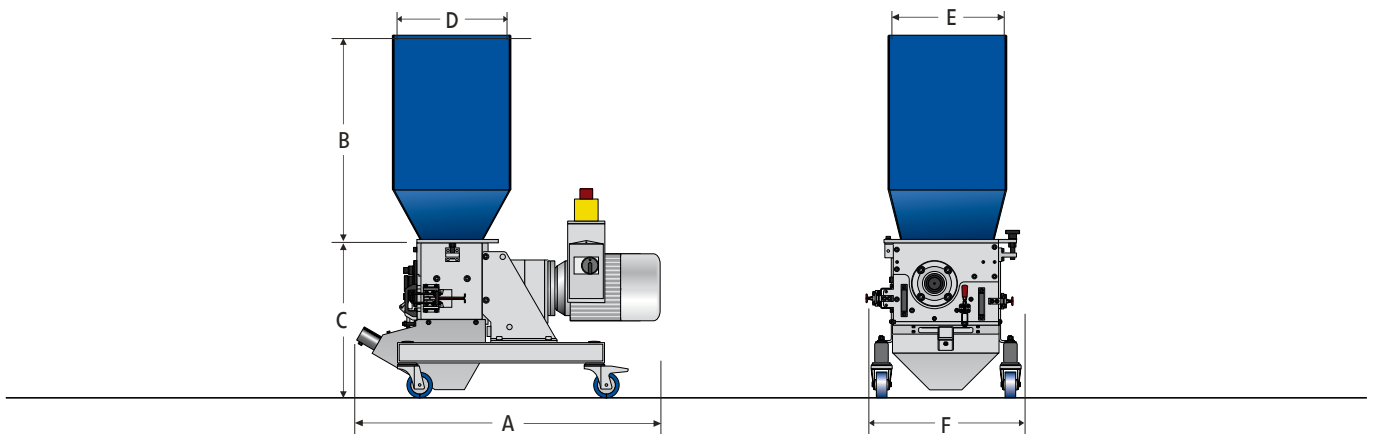



## Series GSL 300

Type	300/400	300/600	300/800
Rotor diameter (mm)	300	300	300
Rotor width (mm)	400	600	800
Rotor speed (rpm)	150	150	150
Drive capacity (kW)	7.5	11	18.5
Rotor knives (pcs)	33	48	66
Stator blades (rows)	2	2	2
Screen size (mm)	> 6	> 6	> 6
Weight approx. (kg)	550	950	1100

## Dimensions

Type	300/400	300/600	300/800
A (mm)	950	1125	820
B (mm)	485	485	485
C (mm)	1280	1280	1280
D (mm)	475	675	900
E (mm)	1035	1230	1635

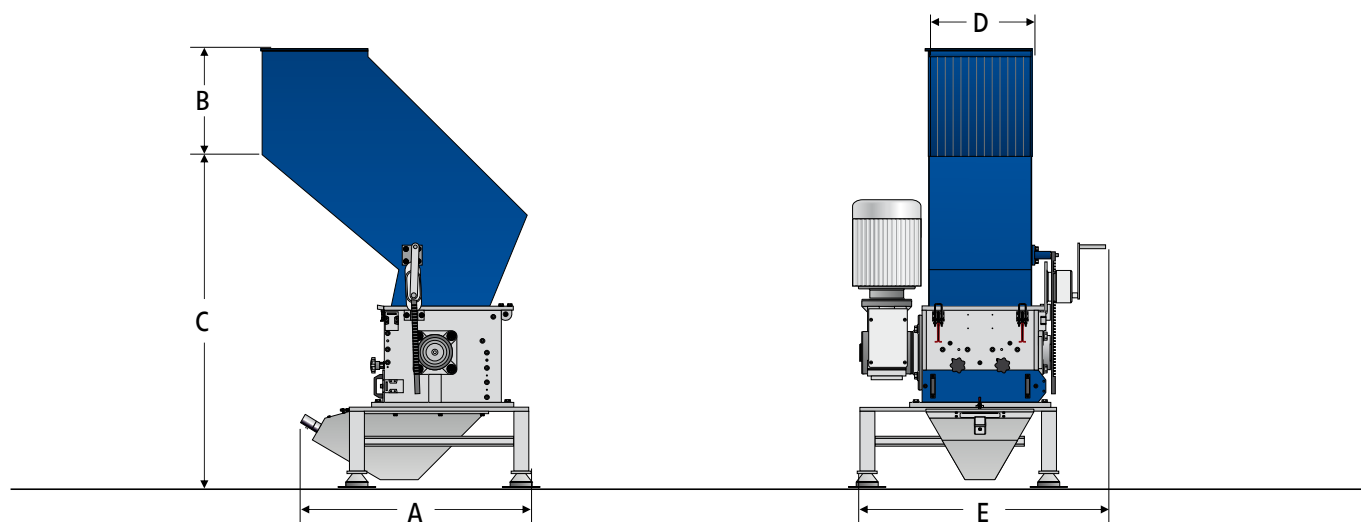

# The right fit for any application

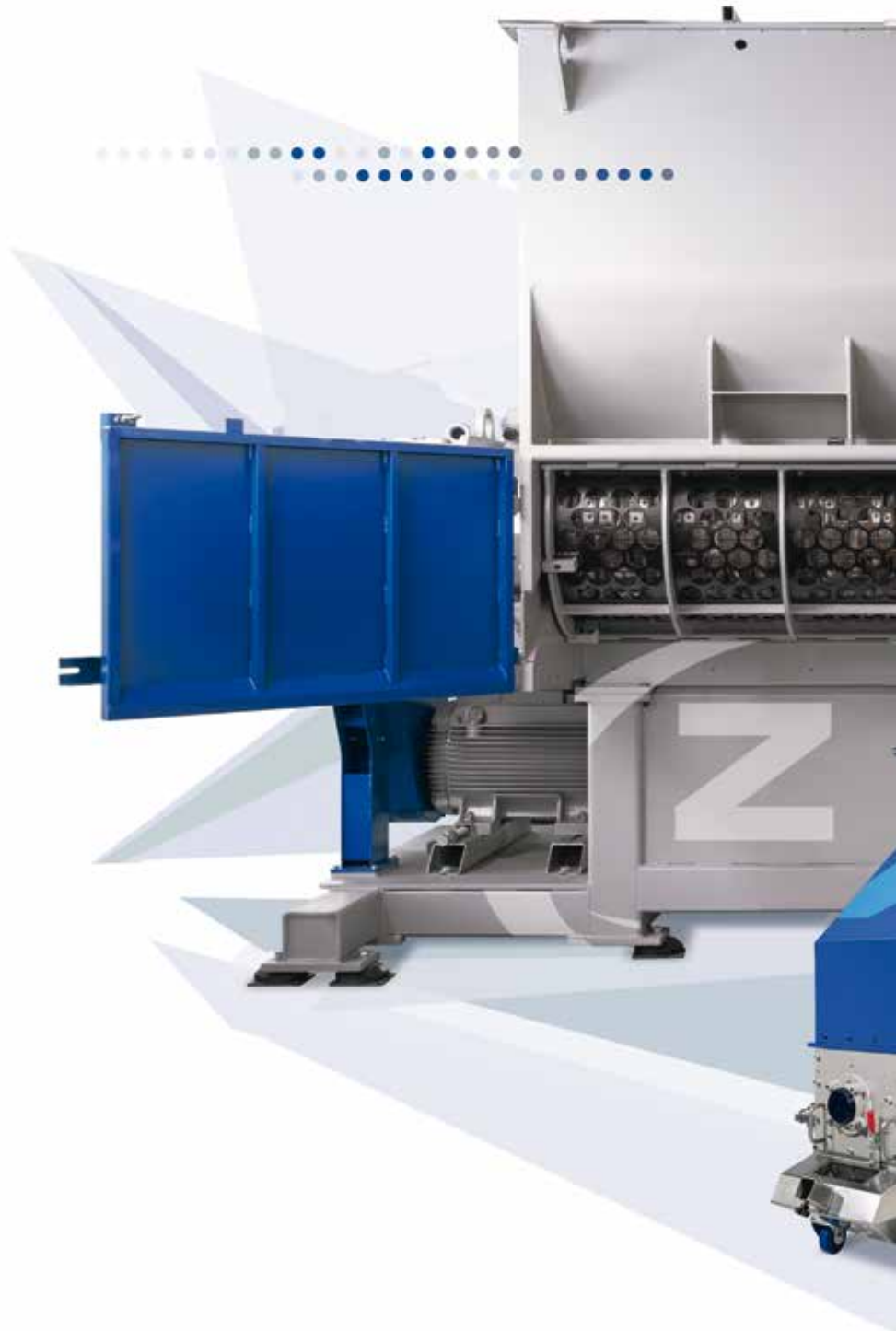

With more than 70 years of experience **ZERMA** is one of the leading producers of high quality size reduction technology, covering the whole spectrum of size reduction starting with the GSL series.



# ZERMA – The Home of Size Reduction



## Close to our customers

The global ZERMA network of branches and distributors



**ZERMA Machinery & Recycling Technology (Shanghai) Co., Ltd**

5 Xinjie Rd · Xinqiao Township Ind. Park

201612 Songjiang · Shanghai · China

Phone: +86 21 57645573 · [info@zerma.com](mailto:info@zerma.com)

[zerma.com](http://zerma.com)